

Lagerprogramm Stahl ■



- **FORMSTAHL / BREITFLANSCHTRÄGER..... - 3 -**
 - U-Stahl | IPE-Träger | HEA | HEB | HEM - 3 -

- **STABSTAHL..... - 4 -**
 - Flachstahl - 5 -
 - Rundstahl - 6 -
 - Vierkantstahl..... - 6 -
 - T-Stahl..... - 7 -
 - U-Stahl - 7 -
 - Winkelstahl - 8 -
 - gleichschenkelig..... - 8 -
 - ungleichschenkelig - 9 -
 - Bandstahl in Stäben - 10 -
 - Breitflachstahl..... - 10 -
 - Spezialprofile - 11 -
 - kaltprofiliert..... - 11 -
 - warmgewalzt - 12 -
 - Blankstahl rund..... - 12 -
 - Qualitätsstahl..... - 12 -

- **ROHRE & ROHRZUBEHÖR..... - 13 -**
 - Quadratrohre - 13 -
 - Rechteckrohre - 14 -
 - Stahlbauhohlprofile..... - 15 -
 - quadratischer Querschnitt - 15 -
 - rechteckiger Querschnitt - 16 -
 - runder Querschnitt..... - 16 -
 - Gewinderohre - 17 -
 - Konstruktionsrohre - 17 -
 - Stahlrohre, nahtlos - 18 -
 - normalwandig..... - 18 -
 - Nahtlose Präzisionsrohre..... - 18 -
 - Geschweißte Präzisionsrohre - 18 -
 - nahtlose Hydraulikleitungsrohre..... - 18 -

- **FLACHPRODUKTE..... - 20 -**
 - Warmgewalzte Bleche - 20 -
 - Tränenbleche - 22 -
 - Feinbleche..... - 22 -
 - Lochbleche - 23 -
 - Wellengitter - 24 -

- **GITTERROSTE.....- 25 -**
 - Press-Industrierosten..... - 25 -
 - Stufen..... - 25 -
 - Gitterrost-Befestigung..... - 26 -
 - Schweiß-Press-Matte - 26 -
 - Press-Rost-Matte..... - 26 -

- **BETONSTAHL.....- 27 -**
 - Stäbe & Ringe - 27 -
 - Betonstahlmatten..... - 28 -
 - Betonstahl Abstandhalter..... - 29 -

- **FORMSTAHL / BREITFLANSCHTRÄGER**
 - **U-STAHL | IPE-TRÄGER | HEA | HEB**

Werkstoff: **S 235 JR (RSt 37-2) EN 10025**

nach DIN 1026-1 EN 10279

**U-Stahl
rundkantig
schwarz**



Abm. [mm]	kg/m
80	8,90
100	10,90
120	13,70
140	16,40
160	19,30
180	22,50
200	26,00
220	30,00
240	34,00

**U-Stahl
rundkantig
entz. SA 2 ½,
Primer**



Abm. [mm]	kg/m
80	8,90
100	10,90
120	13,70
140	16,40
160	19,30

**U-Stahl
verzinkt**



Abm. [mm]	kg/m
80	9,40
100	11,60
120	14,50
140	17,40

nach DIN 1025-5 EN 10034

**IPE-Träger
mittelbreit
schwarz**



Abm. [mm]	kg/m
80	6,20
100	8,30
120	10,70
140	13,20
160	16,20
180	19,30
200	23,00
220	26,90
240	31,50

**HEA-IPBL
schwarz**



Abm. [mm]	kg/m
100	17,10
120	20,40
140	25,30
160	31,20
180	36,40
200	43,00
220	52,00
240	62,00

**HEA-IPBL
entz. SA 2 ½,
Primer
Rotbraun**



Abm. [mm]	kg/m
100	17,10
120	20,40
140	25,30
160	31,20

FORMSTAHL/BREITFLANSCHTRÄGER
U-STAHL | IPE-TRÄGER | HEA | HEB

nach DIN 1025-2 EN 10034

Werkstoff: **S 235 JR (RSt 37-2) EN 10025**

**HEB-IPB
schwarz**



**HEB-IPB
entz. SA 2 1/2,
Primer
Rotbraun**



Abm. [mm]	kg/m
100	20,90
120	27,40
140	34,50
160	43,70
180	52,50
200	63,00
220	73,00
240	85,00

Abm. [mm]	kg/m
100	20,90
120	27,40
140	34,50
160	43,70

nach DIN 1025-2 EN 10034

Werkstoff: **S 235 JR (RSt 37-2) EN 10025**

**HEM-IPBv
schwarz**



Abm. [mm]	kg/m
100	42,80
120	53,40
140	64,80
160	78,10
180	91,10

STABSTAHL

FLACHSTAHL

nach DIN 1017 EN 10058

Werkstoff: **S 235 JR (RSt 37-2)**

schwarz

Abm. [mm]	kg/m
12 x 6	0,57
16 x 5	0,63
20 x 5	0,79
20 x 6	0,94
20 x 8	1,26
20 x 10	1,57
20 x 15	2,36
25 x 5	0,98
25 x 6	1,18
25 x 8	1,57
25 x 10	1,96
30 x 5	1,18
30 x 6	1,41
30 x 8	1,88
30 x 10	2,36
30 x 12	2,83
30 x 15	3,53
30 x 20	4,71
35 x 5	1,37
35 x 6	1,65
35 x 8	2,20
35 x 10	2,75
40 x 5	1,57
40 x 6	1,88

Abm. [mm]	kg/m
40 x 8	2,51
40 x 10	3,14
40 x 12	3,77
40 x 15	4,71
40 x 20	6,28
40 x 25	7,85
45 x 5	1,77
45 x 8	2,83
45 x 10	3,53
50 x 5	1,96
50 x 6	2,36
50 x 8	3,14
50 x 10	3,93
50 x 12	4,71
50 x 15	5,98
50 x 20	7,85
50 x 25	9,81
50 x 30	11,80
60 x 5	2,36
60 x 6	2,83
60 x 8	3,77
60 x 10	4,71
60 x 12	5,65
60 x 15	7,07

Abm. [mm]	kg/m
60 x 20	9,42
60 x 30	14,10
70 x 5	2,75
70 x 6	3,30
70 x 8	4,40
70 x 10	5,50
70 x 12	6,59
70 x 15	8,25
70 x 20	11,00
80 x 5	3,14
80 x 6	3,77
80 x 8	5,02
80 x 10	6,28
80 x 12	7,54
80 x 15	9,42
80 x 20	12,60
80 x 25	15,70
90 x 8	5,65
90 x 10	7,07
100 x 5	3,93
100 x 6	4,71
100 x 8	6,28
100 x 10	7,85

Abm. [mm]	kg/m
100 x 12	9,42
100 x 15	11,80
100 x 20	15,70
100 x 25	19,60
100 x 30	23,60
120 x 8	7,54
120 x 10	9,42
120 x 12	11,30
120 x 15	14,10
120 x 20	18,80
120 x 25	23,60
130 x 10	10,20
130 x 8	8,16
140 x 8	8,79
140 x 10	11,00
140 x 12	13,20
140 x 15	16,50
140 x 20	22,40
150 x 8	9,42
150 x 10	11,80
150 x 12	14,10
150 x 15	17,70
150 x 20	23,60

entz. SA 2 ½,

Primer Sigmaweld

Abm. [mm]	kg/m
30 x 5	1,18
30 x 6	1,41
40 x 5	1,57
40 x 6	1,88
40 x 8	2,51
50 x 5	1,96
50 x 6	2,36
50 x 10	3,93
60 x 6	2,83

Abm. [mm]	kg/m
60 x 8	3,77
60 x 10	4,71
60 x 15	7,07
80 x 8	5,02
80 x 10	6,28
100 x 8	6,28
100 x 10	7,85

verzinkt

Abm. [mm]	kg/m
30 x 5	1,25
40 x 5	1,66
40 x 6	1,99
40 x 8	2,66
50 x 5	2,08
50 x 8	3,33
50 x 10	4,17
60 x 5	2,50
60 x 6	3,00
60 x 8	4,00

Abm. [mm]	kg/m
60 x 10	4,99
80 x 6	3,99
80 x 8	5,32
80 x 10	6,66
100 x 6	5,04
100 x 8	6,67
100 x 10	8,32
100 x 20	16,64
120 x 10	9,99

STABSTAHL

▪ RUNDSTAHL

nach DIN 1013 EN 10060

Werkstoff: **S 235 JR (RSt 37-2)**



schwarz

Abm. [mm]	kg/m
6	0,22
8	0,40
10	0,62
12	0,89
14	1,21
15	1,39
16	1,58
18	2,00
20	2,47

Abm. [mm]	kg/m
22	2,98
24	3,55
25	3,85
30	5,55
35	7,55
40	9,86
45	12,50
50	15,40

verzinkt

Abm. [mm]	kg/m
10	0,65
12	0,94
16	1,68
20	2,62

entz. SA 2 ½, Primer Sigmaweld

Abm. [mm]	kg/m
20	2,47

▪ VIERKANTSTAHL

nach DIN 1014 EN 10059

Werkstoff: **S 235 JR (RSt 37-2)**

schwarz

Abm. [mm]	kg/m
6	0,28
8	0,50
10	0,79
12	1,13
14	1,54

Abm. [mm]	kg/m
15	1,77
16	2,01
20	3,14
25	4,91
30	7,07

Abm. [mm]	kg/m
40	12,60
50	19,60
60	28,30

entz. SA 2 ½, Primer Sigmaweld

Abm. [mm]	kg/m
20	3,14

verzinkt

Abm. [mm]	kg/m
25	5,20
30	7,64

STABSTAHL

▪ T-STAHL

nach DIN EN 10055

Werkstoff: **S 235 JR (RSt 37-2)**

hochstegig, rundkantig



schwarz

Abm. [mm]	kg/m
20 x 20 x 3	0,88
25 x 25 x 4	1,29
30 x 30 x 4	1,77
40 x 40 x 5	2,96
50 x 50 x 6	4,44

Abm. [mm]	kg/m
60 x 60 x 7	6,23
80 x 80 x 9	10,7
100 x 100 x 11	16,4
120 x 120 x 13	23,2
140 x 140 x 15	31,3

▪ U-STAHL

nach DIN 1026 EN 10279

Werkstoff: **S 235 JR (RSt 37-2)**



schwarz

Abm. [mm]	kg/m
30 x 33 x 5	4,40
40 x 35 x 5	5,02
40 x 20 x 5	2,96
50 x 38 x 5	5,76

Abm. [mm]	kg/m
50 x 25 x 5	3,98
60 x 30 x 6	5,22
65 x 42 x 6	7,30

verzinkt

Abm. [mm]	kg/m
40 x 35 x 5	5,16
50 x 38 x 5	6,11
65 x 42 x 6	7,74

STABSTAHL

- **WINKELSTAHL**
 - **gleichschenkelig**

nach DIN EN 10056

Werkstoff: **S 235 JR (RSt 37-2), rundkantig**

x = auch in HL 12m

schwarz

Abm. [mm]	kg/m
20 x 3	0,88
25 x 3	1,12
25 x 4	1,45
30 x 3	1,36
30 x 4	1,80
30 x 5	2,18
35 x 4	2,10
35 x 5	2,57
40 x 4	2,42
40 x 5	2,97
45 x 5	3,38
50 x 4	3,06
50 x 5	3,77
50 x 6	4,47
50 x 8	5,82
60 x 5	4,57
60 x 6	5,42

Abm. [mm]	kg/m
70 x 7	7,38 x
80 x 6	7,34
80 x 8	9,66 x
80 x 10	11,90
90 x 9	9,00
100 x 8	12,20
100 x 10	15,10 x
100 x 12	17,80
120 x 10	18,09
120 x 12	21,60 x
150 x 10	22,80 x
150 x 12	27,30
150 x 15	33,80
160 x 15	36,20 x
200 x 16	48,50 x

entz.SA 2 ½

Primer Sigmaweld

Abm. [mm]	kg/m
30 x 3	1,36
30 x 5	2,18
40 x 4	2,42
40 x 5	2,97
50 x 5	3,77
60 x 6	5,42
80 x 8	9,66
100 x 10	15,10

verzinkt

Abm. [mm]	kg/m
20 x 3	0,93
30 x 3	1,44
30 x 4	1,89
40 x 4	2,57
40 x 5	3,15
50 x 5	4,00
60 x 6	5,75
70 x 7	7,82
80 x 8	10,24 x
100 x 10	16,01 x

STABSTAHL
WINKELSTAHL

▪ **ungleichschenlig**

nach DIN-EN 10056

Werkstoff: **S 235 JR (RSt 37-2), rundkantig**

x = auch in HL 12m

schwarz

Abm. [mm]	kg/m
30 x 20 x 3	1,10
30 x 20 x 4	1,45
40 x 20 x 4	1,77
45 x 30 x 5	2,77
50 x 30 x 5	2,96
50 x 40 x 5	3,35
60 x 30 x 5	3,37
60 x 40 x 5	3,76
60 x 40 x 6	4,46
70 x 50 x 6	5,41
75 x 50 x 5	4,74
80 x 40 x 6	5,41
80 x 40 x 8	7,07
80 x 60 x 7	7,36
80 x 65 x 6	6,60
80 x 65 x 8	8,66
100 x 50 x 6	6,85
100 x 50 x 8	8,99
100 x 50 x 10	11,10

Abm. [mm]	kg/m
100 x 65 x 9	11,10
100 x 75 x 9	11,80
120 x 80 x 8	12,20
120 x 80 x 10	15,00
120 x 80 x 12	17,80
130 x 65 x 8	11,90
150 x 75 x 9	15,30 x
150 x 75 x 11	18,60
150 x 90 x 10	18,20
150 x 100 x 10	19,00 x
150 x 100 x 12	22,60
160 x 80 x 10	18,20 x
180 x 90 x 10	20,60
200 x 100 x 10	23,00 x
200 x 100 x 12	27,30 x
200 x 100 x 14	31,60 x
200 x 150 x 12	31,85 x

verzinkt

Abm. [mm]	kg/m
60 x 40 x 5	3,99
80 x 40 x 6	5,73
100 x 50 x 6	7,26
100 x 50 x 8	9,53
120 x 80 x 8	13,00
150 x 75 x 9	16,22
180 x 90 x 10	21,84
200 x 100 x 10	24,38

▪ BANDSTAHL IN STÄBEN

nach DIN 1016 EN 10048

Werkstoff: **S 235 JR (RSt 37-2)**

schwarz

Abm. [mm]	kg/m
10 x 3	0,24
16 x 3	0,38
20 x 3	0,47
20 x 4	0,63
25 x 3	0,59
25 x 4	0,79
30 x 3	0,71
30 x 4	0,94
40 x 3	0,94

Abm. [mm]	kg/m
40 x 4	1,26
50 x 3	1,18
50 x 4	1,57
60 x 3	1,41
60 x 4	1,88
80 x 3	1,88
80 x 4	2,51
100 x 3	2,35
100 x 4	3,14

verzinkt

Abm. [mm]	kg/m
20 x 3	0,50
30 x 4	1,00
40 x 4	1,33

STABSTAHL

▪ BREITFLACHSTAHL

nach DIN 59200

Werkstoff: **S 235 JR (RSt 37-2)**

schwarz

Abm. [mm]	kg/m
160 x 8	10,20
160 x 10	12,80
160 x 12	15,40
160 x 15	19,20
160 x 20	25,60
160 x 30	38,40
180 x 8	11,50
180 x 10	14,40
180 x 12	17,30
180 x 15	21,60
180 x 20	28,80
200 x 6	9,60
200 x 8	12,80

Abm. [mm]	kg/m
200 x 10	16,00
200 x 12	19,20
200 x 15	24,00
200 x 20	32,00
200 x 25	39,00
200 x 30	48,00
220 x 10	17,60
220 x 12	21,10
220 x 15	26,40
220 x 20	35,20
240 x 10	19,20
240 x 15	28,80
240 x 20	38,40

Abm. [mm]	kg/m
250 x 10	20,00
250 x 12	24,00
250 x 15	30,00
250 x 20	40,00
300 x 10	24,00
300 x 12	28,80
300 x 15	36,00
300 x 20	48,00
300 x 25	60,00

STABSTAHL

▪ **SPEZIALPROFILE**

▪ **kaltprofiliert**

nach DIN EN 10025

U-BAUSTAHL

Werkstoff: **S 235 JR**

schwarz

Abm. [mm]	kg/m
40 x 25 x 3,0	1,91
40 x 35 x 4,0	3,08
40 x 40 x 3,0	2,61
46 x 45 x 3,0	2,97
50 x 25 x 3,0	2,40

Abm. [mm]	kg/m
50 x 40 x 4,0	3,71
54 x 45 x 4,0	4,14
62 x 45 x 4,0	4,36
70 x 50 x 4,0	4,96
80 x 50 x 5,0	6,48

Abm. [mm]	kg/m
100 x 50 x 5,0	7,26
120 x 60 x 6,0	10,4
140 x 60 x 6,0	11,4
160 x 65 x 6,0	12,8
200 x 80 x 6,0	16,10

nach DIN EN 10025

U-BORDWANDSTAHL

Werkstoff: **S235 JR**

sendzimirverzinkt

Abm. [mm]	kg/m
20 x 20 x 1,5	0,71
21 x 21 x 1,5	0,74
23 x 23 x 1,5	0,82
25 x 25 x 1,5	0,90
28 x 28 x 1,5	1,00

Abm. [mm]	kg/m
30 x 30 x 1,5	1,08
31 x 28 x 1,5	1,03

Profil	Zeichnung	Abmessung [mm]	kg/m
Scheuerleistenprofile		50 x 70 x 35 x 10 x 2,5	3,00
Kipperleistenprofil		34 x 45 x 62 x 32 x 4	4,46
Dungstreuerleiste		50 x 20 x 16 x 3	2,50

STABSTAHL
SPEZIALPROFILE

▪ **warmgewalzt**

nach DIN EN 10025

Werkstoff: **S 235 JR (RSt 37-2)**

- Winkelstahl (scharfkantig)
- T-Stahl
- U-Stahl (scharfkantig - innen rundkantig)
- Rolladen-U-Stahl (i. und a. scharfkantig)
- Z-Stahl (rundkantig, auch scharfkantig)
- Bodenbelag - Winkelstahl
- Hespentstahl
- Handleistenstahl
- Ankerstahl
- Halbrund- / Flachhalbrundstahl
- Markisenstahl

▪ **BLANKSTAHL RUND**

nach EN 10277/78



Werkstoff: **S355 J2C+C h9**

Werkstoff: **C45+C h6
geschliffen**

Werkstoff: **C45+C h9**

Abm. [mm]	kg/m
5	0,15
6	0,22
8	0,71
10	0,62
12	0,89
14	1,21
15	1,39
16	1,58
18	2,00
20	2,47
22	2,98

Abm. [mm]	kg/m
25	3,85
28	4,83
30	5,55
35	7,55
40	9,86
45	12,50
50	15,40
60	22,20
70	30,20
80	39,50
100	61,70

Abm. [mm]	kg/m
30	5,55
40	9,86

Abm. [mm]	kg/m
25	3,85

▪ **QUALITÄTSSTAHL**

nach DIN EN 10025-2

Werkstoff: **S355 J2**

flach, schwarz

Abm. [mm]	kg/m
40 x 20	6,28
50 x 15	5,89

Weitere Dimensionen und Werkstoffe auf Anfrage.
Bitte sprechen Sie uns an!

▪ ROHRE & ROHRZUBEHÖR

▪ QUADRATROHRE

nach EN 10305-5 / EN 10219

Werkstoff: **S235**

schwarz

Abm. [mm]	kg/m
15 x 15 x 1,5	0,63
15 x 15 x 2,0	0,81
20 x 20 x 2,0	1,12
20 x 20 x 3,0	1,60
25 x 25 x 2,0	1,44
25 x 25 x 3,0	1,92
30 x 30 x 2,0	1,75
30 x 30 x 3,0	2,39
30 x 30 x 4,0	3,32
34 x 34 x 2,0	2,00
35 x 35 x 2,0	2,07
35 x 35 x 3,0	2,95
40 x 40 x 2,0	2,38
40 x 40 x 3,0	3,33
40 x 40 x 4,0	4,25
40 x 40 x 5,0	5,50
45 x 45 x 2,0	2,69
50 x 50 x 2,0	3,01
50 x 50 x 3,0	4,28
50 x 50 x 4,0	5,51
50 x 50 x 5,0	6,55

verzinkt

Abm. [mm]	kg/m
20 x 20 x 2,0	1,22
25 x 25 x 2,0	1,56
30 x 30 x 2,0	1,90
34 x 34 x 2,0	2,17
40 x 40 x 2,0	2,58
40 x 40 x 3,0	3,64
40 x 40 x 4,0	4,51
50 x 50 x 2,0	3,25
50 x 50 x 3,0	4,63
50 x 50 x 4,0	6,01
60 x 60 x 2,0	3,93
60 x 60 x 3,0	5,63
60 x 60 x 4,0	7,31
60 x 60 x 5,0	8,90
70 x 70 x 4,0	8,62
80 x 80 x 3,0	7,62
80 x 80 x 4,0	9,93
90 x 90 x 3,0	8,61
100 x 100 x 3,0	9,60
100 x 100 x 4,0	12,54

ROHRE & ROHRZUBEHÖR

RECHTECKROHRE

nach EN 10305-5 / EN 10219

Werkstoff: **S235 JRH**

schwarz

Abm. [mm]	kg/m
20 x 10 x 2,0	0,81
30 x 15 x 2,0	1,28
30 x 20 x 2,0	1,44
30 x 20 x 3,0	2,07
30 x 25 x 2,0	1,59
40 x 15 x 2,0	1,59
40 x 20 x 2,0	1,59
40 x 20 x 3,0	2,39
40 x 25 x 2,0	1,91
40 x 30 x 2,0	2,07
40 x 30 x 3,0	2,86
50 x 20 x 2,0	2,07
50 x 25 x 2,0	2,22
50 x 25 x 3,0	3,10
50 x 30 x 2,0	2,38
50 x 30 x 3,0	3,33
50 x 30 x 4,0	4,25
50 x 40 x 2,0	2,69
50 x 40 x 3,0	3,80
55 x 34 x 2,0	2,66
60 x 20 x 2,0	2,38
60 x 30 x 2,0	3,80
60 x 30 x 3,0	3,80
60 x 30 x 4,0	4,88
60 x 40 x 2,0	3,01
60 x 40 x 3,0	4,28
60 x 40 x 4,0	5,51
60 x 40 x 5,0	6,56
60 x 50 x 4,0	6,14
70 x 40 x 3,0	4,75
70 x 40 x 4,0	6,14
70 x 50 x 3,0	4,75
70 x 50 x 4,0	6,76
80 x 20 x 2,0	3,01

verzinkt

Abm. [mm]	kg/m
30 x 20 x 2,0	1,56
40 x 20 x 2,0	1,90
40 x 30 x 3,0	3,16
50 x 30 x 2,0	2,58
50 x 40 x 3,0	4,16
60 x 30 x 2,0	2,92
60 x 30 x 3,0	4,16
60 x 30 x 4,0	5,27
60 x 40 x 2,0	3,25
60 x 40 x 3,0	4,63
80 x 20 x 2,0	3,01
80 x 40 x 2,0	3,93
80 x 40 x 3,0	5,63
80 x 40 x 4,0	7,31
80 x 50 x 3,0	6,13
80 x 50 x 4,0	7,97
100 x 20 x 3,0	5,64
100 x 30 x 3,0	6,13
100 x 40 x 3,0	6,63
100 x 40 x 5,0	10,48
100 x 50 x 3,0	7,12
100 x 50 x 5,0	11,32
100 x 50 x 6,0	13,13
120 x 50 x 5,0	14,69
120 x 60 x 6,0	15,75
160 x 80 x 3,0	11,05
160 x 80 x 5,0	18,42
160 x 80 x 8,0	28,00
160 x 80 x 10,0	35,72

Weitere Dimensionen und Werkstoffe auf Anfrage.
 Bitte sprechen Sie uns an!

ROHRE & ROHRZUBEHÖR

- **STAHLBAUHOHLPROFILE**
 - **quadratischer Querschnitt**

nach DIN EN 10219 (DIN 59411)

HL 6m / 12m

Werkstoff: **S235 JRH**

Abm. [mm]	kg/m
40 x 40 x 3,0	3,33
60 x 60 x 5,0	8,13
60 x 60 x 6,0	9,45
80 x 80 x 3,0	7,10
80 x 80 x 4,0	9,28
80 x 80 x 6,0	12,97
90 x 90 x 6,0	14,85
100 x 100 x 3,0	8,99
100 x 100 x 4,0	11,70
100 x 100 x 5,0	14,40
100 x 100 x 6,0	16,73
100 x 100 x 8,0	22,70
110 x 110 x 5,0	15,81
120 x 120 x 3,0	10,90
120 x 120 x 4,0	14,40

Werkstoff: **S 355 J2H**

Abm. [mm]	kg/m
120 x 120 x 5,0	17,80
120 x 120 x 6,0	20,51
140 x 140 x 4,0	16,26
140 x 140 x 5,0	20,52

Abm. [mm]	kg/m
40 x 40 x 3,0	3,33
40 x 40 x 4,0	4,25
50 x 50 x 4,0	5,51
50 x 50 x 5,0	6,55
60 x 60 x 4,0	6,93
60 x 60 x 8,0	12,50
70 x 70 x 5,0	8,18
70 x 70 x 6,0	11,80
80 x 80 x 3,0	7,10
80 x 80 x 4,0	9,28
80 x 80 x 5,0	11,30
80 x 80 x 6,0	12,97
80 x 80 x 8,0	17,70
100 x 100 x 5,0	14,40
100 x 100 x 8,0	22,70
100 x 100 x 10,0	25,60
120 x 120 x 4,0	14,40
120 x 120 x 8,0	27,40

ROHRE & ROHRZUBEHÖR
STAHLBAUHOHLPROFIL

▪ **rechteckiger Querschnitt**

nach DIN EN 10219 (DIN 59411)

HL 6m / 12m

Werkstoff: **S 235 JRH**

Werkstoff: **S 355 J2H**

Abm. [mm]	kg/m
100 x 60 x 3,0	7,10
100 x 60 x 6,0	12,96
120 x 60 x 4,0	10,50
140 x 40 x 4,0	10,30
140 x 40 x 5,0	12,33
140 x 60 x 3,0	9,14
140 x 60 x 4,0	11,70
140 x 60 x 6,0	17,00
140 x 80 x 5,0	16,20
140 x 80 x 4,0	12,99
150 x 100 x 4,0	14,90
150 x 100 x 5,0	14,90
160 x 60 x 3,0	9,90
160 x 80 x 4,0	14,20
160 x 80 x 5,0	17,38
200 x 40 x 3,0	10,77
200 x 80 x 4,0	16,80
200 x 100 x 4,0	18,01
200 x 100 x 5,0	22,10
200 x 100 x 6,0	26,15

Abm. [mm]	kg/m
60 x 40 x 3,0	4,28
60 x 40 x 5,0	9,00
70 x 50 x 5,0	8,13
80 x 40 x 4,0	6,76
80 x 50 x 3,0	5,66
80 x 50 x 5,0	8,91
80 x 60 x 5,0	9,70
80 x 60 x 6,0	11,00
80 x 80 x 6,0	12,97
100 x 50 x 6,0	12,00
100 x 60 x 5,0	11,60
100 x 80 x 6,0	15,10
120 x 60 x 6,0	14,86
120 x 80 x 4,0	11,95
120 x 80 x 6,0	16,73
120 x 80 x 8,0	21,39
140 x 80 x 6,0	18,62
160 x 80 x 5,0	17,50
160 x 80 x 6,0	20,51
160 x 80 x 8,0	26,41

Abm. [mm]	kg/m
180 x 80 x 8,0	28,91
180 x 100 x 8,0	31,43
200 x 100 x 8,0	24,28
200 x 100 x 8,0	33,95
200 x 150 x 10,0	50,30
260 x 180 x 10,0	63,90

▪ **runder Querschnitt**

nach DIN EN 10219

Werkstoff: **S235 JRH**

Abm. [mm]	kg/m
26,9 x 3,0	1,77
33,7 x 2,0	1,56
33,7 x 3,2	2,44
42,4 x 2,0	1,99
42,4 x 3,2	3,14
42,4 x 4,0	3,79
48,0 x 2,0	2,27
48,3 x 3,2	3,61

Abm. [mm]	kg/m
48,3 x 4,0	4,41
48,3 x 5,0	5,34
60,3 x 3,6	5,10
60,3 x 4,0	5,50
60,3 x 5,0	6,82
60,3 x 6,3	8,39
76,1 x 2,9	5,24
76,1 x 3,6	6,52

Abm. [mm]	kg/m
88,9 x 2,9	6,20
88,9 x 3,2	6,76
88,9 x 4,0	8,47
88,9 x 5,0	1,30
101,6 x 2,9	7,06
101,6 x 3,6	8,70
101,6 x 4,0	9,63
101,6 x 5,0	11,90

Abm. [mm]	kg/m
114,3 x 3,6	9,83
139,7 x 5,0	16,60
159,0 x 4,5	17,10
168,3 x 4,5	20,14
219,1 x 4,5	23,82

Weitere Dimensionen und Werkstoffe auf Anfrage.
Bitte sprechen Sie uns an!

ROHRE & ROHRZUBEHÖR

■ GEWINDEROHRE

nach DIN-EN 10255 (DIN 2440) o/o

Werkstoff: **S195 T**

schwarz

HL 6m geschw.

Abmessung [mm]	kg/m
1/2 (21,3 x 2,6)	1,22
3/4 (26,9 x 2,6)	1,58
1 (33,7 x 3,2)	2,44
1 1/4 (42,4 x 3,2)	3,14
1 1/2 (48,3 x 3,2)	3,61
2 (60,3 x 3,6)	5,10
2 1/2 (76,1 x 3,6)	6,52
3 (88,9 x 4)	8,47
4 (144,3 x 4,5)	12,10

schwarz

HL 5-7m nahtlos

Abmessung [mm]	kg/m
3/4 (27,9 x 2,6)	1,58
1 (33,7 x 3,2)	2,44
1 1/4 (42,4 x 3,2)	3,14
1 1/2 (48,3 x 3,2)	3,61
2 (60,3 x 3,6)	5,10
2 1/2 (76,1 x 3,6)	6,52
3 (88,9 x 4,0)	8,47

schwarz streckreduziert

HL 6m geschw.

Abmessung [mm]	kg/m
1 (33,7 x 3,2)	2,55
1 1/4 (42,4 x 3,2)	3,14
1,5 (48,3 x 3,2)	3,61
2 (60,3 x 3,6)	5,10

verzinkt

HL 6m geschw.

Abmessung [mm]	kg/m
1/2 (21,3 x 2,6)	1,27
3/4 (26,9 x 2,6)	1,65
1 (33,7 x 3,2)	2,55
1 1/4 (42,4 x 3,2)	3,28
1 1/2 (48,3 x 3,2)	3,77
2 (60,3 x 3,6)	5,33
2 1/2 (76,1 x 3,6)	6,80
3 (88,9 x 4,0)	8,85
4 (114,3 x 4,5)	12,64

verzinkt

HL 5-7m nahtlos

Abmessung [mm]	kg/m
1/2 (21,3 x 2,6)	1,27
3/4 (26,9 x 2,6)	1,65
1 (33,7 x 3,2)	2,55
1 1/4 (42,4 x 3,2)	3,28
1 1/2 (48,3 x 3,2)	3,77
2 (60,3 x 3,6)	5,33

■ KONSTRUKTIONSRHRE

nach DIN EN

Werkstoff: **S235 JRH**

elektrisch geschweißt, rohschwarz

Abmessung [mm]	kg/m
1/2 (21,3 x 2,0)	0,96
3/4 (26,9 x 2,0)	1,24
1 (33,7 x 2,5)	1,92

Abmessung [mm]	kg/m
1 1/4 (42,4 x 2,5)	2,46
1 1/2 (48,3 x 2,5)	2,82
2 (60,3 x 2,5)	3,56

ROHRE & ROHRZUBEHÖR

- **STAHLROHRE, NAHTLOS**
 - **normalwandig**

nach DIN EN 10220 / 10216

Werkstoff: **P235 / S355J2H**

HL 4 – 7 m

Abm. [mm]	kg/m
21,3 x 2,6	1,19
21,3 x 2,9	1,32
26,9 x 2,3	1,40
26,9 x 5,0	2,70
33,7 x 4,0	2,93
33,7 x 6,3	4,26
38,0 x 2,6	2,27
38,0 x 4,0	3,35
38,0 x 6,3	14,60
42,4 x 3,2	3,09
42,4 x 5,0	4,61
48,3 x 3,2	3,56

Abm. [mm]	kg/m
48,3 x 3,6	3,97
48,3 x 4,0	4,37
51,0 x 2,6	3,10
51,0 x 10,0	10,11
60,3 x 2,9	4,11
60,3 x 4,5	6,19
60,3 x 16,0	17,48
70,0 x 2,9	4,80
70,0 x 5,6	8,89
76,1 x 2,9	5,24
76,1 x 8,8	14,60
88,9 x 3,2	6,76

Abm. [mm]	kg/m
88,9 x 4,5	9,37
88,9 x 5,0	10,30
88,9 x 8,0	16,00
88,9 x 20,0	34,00
101,6 x 3,6	8,70
108,0 x 3,6	9,27
114,3 x 3,6	8,83
139,7 x 4,0	13,40
159,0 x 4,5	17,10
168,3 x 4,5	18,20
219,1 x 6,3	32,10

- **NAHTLOSE PRÄZISIONSROHRE**

nach DIN EN 10305-1

Werkstoff: **E 235 + C**

HL 4 - 7 m

Abm. [mm]	kg/m
16,0 x 2,8	0,91
20,0 x 4,5	1,72
22,0 x 2,8	1,33
25,0 x 3,5	1,81
27,0 x 3,0	1,76
35,0 x 4,0	3,06

- **GESCHWEIßTE PRÄZISIONSROHRE**

nach DIN EN 10305-2

Werkstoff: **E 235 + C**

HL 4 – 7 m

Abm. [mm]	kg/m
65,0 x 7,5	10,63

ROHRE & ROHRZUBEHÖR

▪ **NAHTLOSE HYDRAULIKLEITUNGSROHRE**

nach DIN EN 10305-4

Werkstoff: **E 235 + N**

außen galvanisch

verzinkt

phosphatiert

Abm. [mm]	kg/m
8,0 x 1,0	0,200
10,0 x 1,5	0,320
12,0 x 1,0	0,275
12,0 x 1,5	0,388
15,0 x 1,5	0,500
16,0 x 2,0	0,690
20,0 x 2,0	0,888

Abm. [mm]	kg/m
16,0 x 2,0	0,690
18,0 x 2,0	0,800
20,0 x 2,5	0,890
28,0 x 2,5	1,570
35,0 x 5,0	3,700

- **FLACHPRODUKTE**
 - **WARMGEWALZTE BLECHE**

nach DIN EN 10051 / 10029

Werkstoff: **S 235 JR**

schwarz

Abmessung [mm]
3,0 x 1.000 x 2.000
3,0 x 1.250 x 2.500
3,0 x 1.500 x 3.000
4,0 x 1.000 x 2.000
4,0 x 1.250 x 2.500
4,0 x 1.500 x 3.000
5,0 x 1.000 x 2.000
5,0 x 1.250 x 2.500
5,0 x 1.500 x 3.000
6,0 x 1.000 x 2.000
6,0 x 1.250 x 2.500
6,0 x 1.500 x 3.000
8,0 x 1.000 x 2.000
8,0 x 1.250 x 2.500
8,0 x 1.500 x 3.000
10,0 x 1.000 x 2.000

nach DIN EN 10051

Werkstoff: **S 355 MC**

schwarz

Abmessung [mm]
3,0 x 1.250 x 2.500
3,0 x 1.500 x 3.000
4,0 x 1.250 x 2.500
4,0 x 1.500 x 3.000
5,0 x 1.250 x 2.500
5,0 x 1.500 x 3.000
6,0 x 1.250 x 2.500
6,0 x 1.500 x 3.000
8,0 x 1.250 x 2.500
8,0 x 1.500 x 3.000
10,0 x 1.250 x 2.500
10,0 x 1.500 x 3.000
12,0 x 1.500 x 3.000
15,0 x 1.500 x 3.000
20,0 x 1.500 x 3.000

nach DIN EN 10051

Werkstoff: **S 235 JR**

gebeizt und geölt

Abmessung [mm]
3,0 x 1.500 x 3.000
5,0 x 1.500 x 3.000
6,0 x 1.500 x 3.000
8,0 x 1.500 x 3.000
10,0 x 1.500 x 3.000
12,0 x 1.500 x 3.000
15,0 x 1.500 x 3.000

nach DIN EN 10051

Werkstoff: **S 355 MC**

gebeizt und geölt

Abmessung [mm]
3,0 x 1.500 x 3.000
4,0 x 1.500 x 3.000
5,0 x 1.500 x 3.000
6,0 x 1.500 x 3.000
8,0 x 1.500 x 3.000

Weitere Dimensionen und Werkstoffe auf Anfrage.
 Bitte sprechen Sie uns an!

- **FLACHPRODUKTE**
 - **WARMGEWALZTE BLECHE**

nach DIN EN 10051
Werkstoff: **S 355J2+N**

Abmessung [mm]
3,0 x 1.500 x 3.000
4,0 x 1.500 x 3.000
5,0 x 1.500 x 3.000
6,0 x 1.500 x 3.000
8,0 x 1.500 x 3.000
10,0 x 1.500 x 3.000
12,0 x 1.500 x 3.000
15,0 x 1.500 x 3.000
20,0 x 1.000 x 2.000
20,0 x 1.500 x 2.000

nach DIN EN 10051
Werkstoff: **S700 MC**

Abmessung [mm]
3,0 x 1.250 x 2.500
3,0 x 1.500 x 3.000
4,0 x 1.250 x 2.500
4,0 x 1.500 x 3.000
5,0 x 1.250 x 2.500
5,0 x 1.500 x 3.000
6,0 x 1.250 x 2.500
6,0 x 1.500 x 3.000
8,0 x 1.500 x 3.000
10,0 x 1.500 x 3.000

nach DIN EN 10029
Werkstoff: **P 265 GH**

Abmessung [mm]
5,0 x 1.500 x 3.000
6,0 x 1.500 x 3.000
8,0 x 1.500 x 3.000
10,0 x 1.500 x 3.000
12,0 x 1.500 x 3.000
15,0 x 1.500 x 3.000
20,0 x 1.500 x 3.000
25,0 x 1.500 x 3.000
30,0 x 1.500 x 3.000
40,0 x 1.500 x 3.000

- **FLACHPRODUKTE**
 - **TRÄNENBLECHE**

nach DIN 59220

Werkstoff: **S 235 JR**

schwarz

Abmessung [mm]
3,00 x 1.000 x 2.000
3,00 x 1.250 x 2.500
3,00 x 1.500 x 3.000
4,00 x 1.000 x 2.000
4,00 x 1.250 x 2.500
4,00 x 1.500 x 3.000

Abmessung [mm]
5,00 x 1.000 x 2.000
5,00 x 1.250 x 2.500
5,00 x 1.500 x 3.000
6,00 x 1.000 x 2.000
6,00 x 1.250 x 2.500
6,00 x 1.500 x 3.000

Abmessung [mm]
8,00 x 1.000 x 2.000
8,00 x 1.250 x 2.500
10,00 x 1.000 x 2.000
10,00 x 1.250 x 2.500
10,00 x 1.500 x 3.000

■ FEINBLECHE

nach DIN EN 10143

nach DIN EN 10130

kaltgewalzt DC01

Abmessung [mm]
0,75 x 1.000 x 2.000
1,00 x 1.000 x 2.000
1,00 x 1.250 x 2.500
1,00 x 1.500 x 3.000
1,25 x 1.000 x 2.000
1,50 x 1.000 x 2.000
1,50 x 1.250 x 2.500
1,50 x 1.500 x 3.000
2,00 x 1.000 x 2.000
2,00 x 1.250 x 2.500
2,00 x 1.500 x 3.000
2,99 x 1.250 x 2.500
2,99 x 1.500 x 3.000

nach DIN EN 10051

warmgewalzt DD11

Abmessung [mm]
2,00 x 1.000 x 2.000
2,00 x 1.250 x 2.500
2,00 x 1.500 x 3.000
2,50 x 1.000 x 2.000
2,50 x 1.250 x 2.500
2,50 x 1.500 x 3.000
2,99 x 1.000 x 2.000
2,99 x 1.250 x 2.500
2,99 x 1.500 x 3.000
4,00 x 1.250 x 2.500
4,00 x 1.500 x 3.000
5,00 x 1.500 x 3.000
6,00 x 1.250 x 2.500

Abmessung [mm]
6,00 x 1.500 x 3.000
8,00 x 1.250 x 2.500
8,00 x 1.500 x 3.000
10,00 x 1.500 x 3.000
12,00 x 1.500 x 3.000

feuerverzinkt DX51D+Z

Abmessung [mm]
0,50 x 1.000 x 2.000
0,63 x 1.000 x 2.000
0,75 x 1.000 x 2.000
0,75 x 1.500 x 3.000
0,88 x 1.000 x 2.000
1,00 x 1.000 x 2.000
1,00 x 1.250 x 2.500
1,00 x 1.500 x 3.000

Abmessung [mm]
1,50 x 1.250 x 2.500
1,50 x 1.500 x 3.000
2,00 x 1.000 x 2.000
2,00 x 1.250 x 2.500
2,00 x 1.500 x 3.000
2,50 x 1.000 x 2.000
2,50 x 1.250 x 2.500
2,50 x 1.500 x 3.000

Abmessung [mm]
2,99 x 1.250 x 2.500
2,99 x 1.500 x 3.000
4,00 x 1.250 x 2.500
4,00 x 1.500 x 3.000
5,00 x 1.500 x 3.000

FLACHPRODUKTE

■ FEINBLECHE

nach DIN EN 10131

eilverzinkt DC01+ZE

Abmessung [mm]
1,00 x 1.250 x 2.500
1,00 x 1.500 x 3.000
1,50 x 1.250 x 2.500
1,50 x 1.500 x 3.000
2,00 x 1.500 x 3.000
2,99 x 1.500 x 3.000

▪ LOCHBLECHE

nach DIN 24041

schwarz

Abmessung [mm]	Lochung [mm]	kg/Tfl.
1,5 x 1.000 x 2.000	RV 5-8	15,20
1,5 x 1.000 x 2.000	QG 10-14	11,60
1,5 x 1.000 x 2.000	QG 10-15	13,36
1,5 x 1.500 x 3.000	QG 10-15	30,66
2,0 x 1.000 x 2.000	RV 8-12	19,00
2,0 x 1.000 x 2.000	QG 8-10	15,40
2,0 x 1.000 x 2.000	QG 10-15	17,40

verzinkt

Abmessung [mm]	Lochung [mm]	kg/Tfl.
1,0 x 1.250 x 2.500	RV 4-6	14,70
1,0 x 1.500 x 3.000	RV 4-6	21,20
1,0 x 1.000 x 2.000	RV 5-8	10,20
1,0 x 1.250 x 2.500	RV 5-8	13,00
1,0 x 1.500 x 3.000	RV 5-8	22,60
1,5 x 1.000 x 2.000	RV 5-8	15,20
1,5 x 1.500 x 3.000	RV 5-8	34,20
1,5 x 1.000 x 2.000	RV 8-12	14,00
1,5 x 1.500 x 3.000	RV 8-12	31,50
1,5 x 1.000 x 2.000	QG10-15	13,00
1,5 x 1.250 x 2.500	QG10-15	22,00
1,5 x 1.500 x 3.000	QG10-15	29,30
2,0 x 1.000 x 2.000	QG10-15	17,40

▪ WELLENGITTER

nach DIN 4192

schwarz

Abmessung [mm]	MW [mm]	kg/Tfl.
4,0 x 1.000 x 2.000	40 x 40	9,40
4,0 x 1.250 x 2.500	40 x 40	14,70
4,0 x 1.500 x 3.000	40 x 40	21,20

verzinkt

Abmessung [mm]	MW [mm]	kg/Tfl.
4,0 x 1.000 x 2.000	40 x 40	9,40
4,0 x 1.250 x 2.500	40 x 40	14,70
4,0 x 1.500 x 3.000	40 x 40	21,20

- **GITTERROSTE**
 - **PRESS-INDUSTRIEROSTEN**

Werkstoff: **S235 JR**

verzinkt, Maschenweite 30 x 30 mm

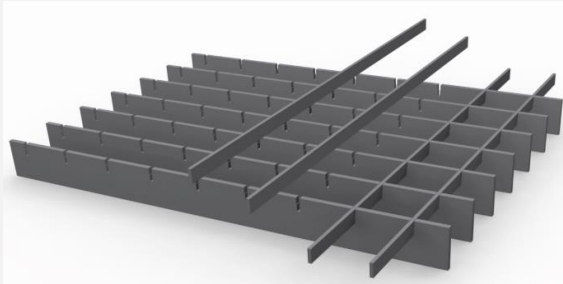

Abm. [mm]	kg/Stk.	Tragstab [mm]
500 x 1.000	8,02	30 x 2
600 x 1.000	9,44	30 x 2
600 x 1.000	14,87	30 x 3
800 x 1.000	13,42	30 x 2
1.000 x 1.000	16,55	30 x 2
1.000 x 1.000	24,24	30 x 3

- **STUFEN**

Werkstoff: **S235 JR**

verzinkt, Maschenweite 30 x 30 mm / Maschenweite 30 x 10 mm



Abm. [mm]	kg/Stk.	Tragstab [mm]	Maschenweite [mm]
600 x 270	3,73	30 x 2	30 x 30
800 x 240	4,24	30 x 2	30 x 30
800 x 270	5,59	30 x 2	30 x 10
800 x 270	4,72	30 x 2	30 x 30
1.000 x 270	7,66	35 x 2	30 x 10
1.000 x 270	7,04	35 x 2	30 x 30

GITTERROSTE

▪ GITTERROST-BEFESTIGUNG

Werkstoff: **S235 JR**
verzinkt (Teller, Lasche, Schraube)

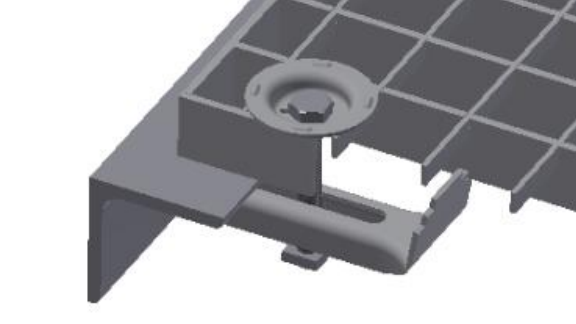

▪ SCHWEIß-PRESS-MATTE

Werkstoff: **S235 JR**
roh/schwarz, Maschenweite 30 x 30 mm

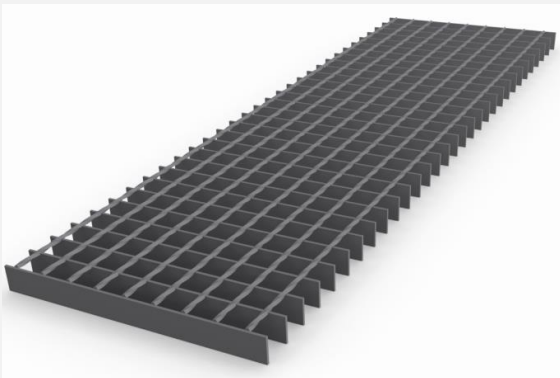

Abm. [mm]	kg/Stk.	Tragstab [mm]
6.100 x 1.000	142,97	30 x 3
6.100 x 1.000	194,63	40 x 3

▪ PRESS-ROST-MATTE

Werkstoff: **S235 JR**
roh/schwarz, GS = Gleitschutz



Abm. [mm]	kg/Stk.	Tragstab [mm]	Maschenweite [mm]
3.000 x 1.000	64,58	30 x 2	30 x 30
3.000 x 1.000	65,40	30 x 2	30 x 10 GS
3.000 x 1.000	69,00	30 x 2	30 x 10
3.000 x 1.000	70,80	30 x 3	30 x 30
3.000 x 1.000	79,20	30 x 3	30 x 30 GS

▪ BETONSTAHL

▪ STÄBE & RINGE

nach DIN 488

Werkstoff: **B500B (Stäbe)**

bzw. **WR/KR (Ringe)**

Abm. [mm]	Handelslängen [m]							
	6	7	11	12	13	14	15	16
6,00	x			x				
8,00		x				x		
10,00		x	x	x		x	x	
12,00		x		x		x	x	
14,00		x		x		x	x	x
16,00		x		x		x	x	x
20,00				x	x	x	x	x
25,00				x		x	x	x
28,00				x		x	x	x

Ringe

Abm. [mm]	kg/m
6,00	0,22
8,00	0,40
10,00	0,62
12,00	0,89
14,00	1,21
16,00	1,58

feuerverzinkt

HL 6m

Abm. [mm]	kg/m
6,00	0,20

■ BETONSTAHLMATTEN

nach DIN 488

Werkstoff: **B500 A / B**

Matten- größe	Mattenbe- zeichnung	Gewicht		Abstände		Durchmesser		Stahlquerschnitt	
		[kg/m ²]	[kg/Stk.]	Längs- stäbe [mm]	Quer- stäbe [mm]	Längs- stäbe [mm]	Quer- stäbe [mm]	Längs- stäbe [cm ² /m]	Quer- stäbe [cm ² /m]
Abm. [m]									
5,00 x 2,15	Q 131	2,09	22,50	150	150	5,0	5,0	1,31	1,31
6,00 x 2,30	Q 188 A	3,02	41,70	150	150	6,0	6,0	1,88	1,88
	Q 257 A	4,12	56,80	150	150	7,0	7,0	2,57	2,57
	Q 335 A	5,38	74,30	150	150	8,0	8,0	3,35	3,35
	Q 424 A	6,12	84,40	150	150	9,0	9,0	4,24	4,24
	Q 524 A	7,31	100,90	150	150	10,0	10,0	5,24	5,24
6,00 x 2,35	Q 636 A	9,36	132,00	100	125	9,0	10,0	6,36	6,28
6,00 x 2,30	R 188 A	2,43	33,60	150	250	6,0	6,0	1,88	1,13
	R 257 A	2,99	41,20	150	250	7,0	6,0	2,57	1,13
	R 335 A	3,64	50,20	150	250	8,0	6,0	3,35	1,13
	R 424 A	4,87	67,20	150	250	9,0	8,0	4,24	2,01
	R 524 A	5,49	75,70	150	250	10,0	8,0	5,24	2,01

BETONSTAHL

▪ BETONSTAHL ABSTANDHALTER

Korblänge L = 2,0 m

Sichtbetonabstandhalter, Distanzträger "DT"

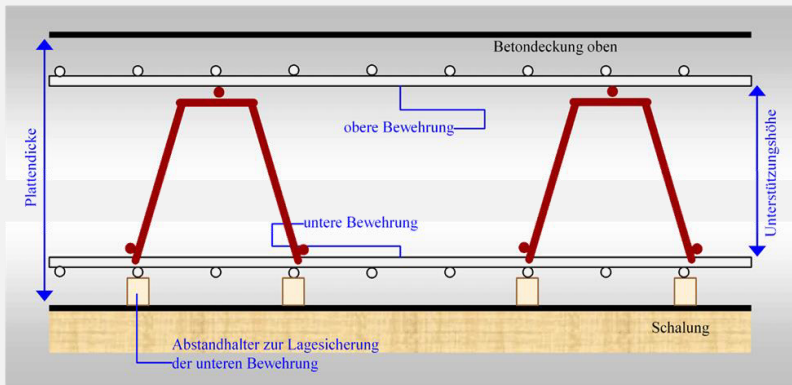

Unterstützungskörbe Dista-Schlangen

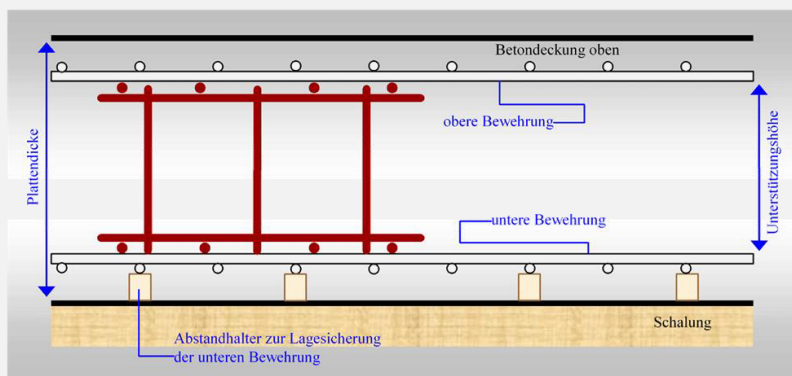

U-Höhe cm	Dista
5	●
6	●
7	●
8	●
9	●
10	●
11	●
12	●
14	●
16	●
18	●
20	●
22	●
24	●

Außerdem:

- Drunterleisten (offen / geschlossen)
- Verzinkter Bandstahl in Ringen Z500 sowie verzinkte Keilverbinder
- Bindedrahtröllchen, schwarz 1,4 mm
- Eisendraht gegläht in Ringen (1,4 – 6,0 mm)

Weitere Dimensionen und Werkstoffe auf Anfrage. Bitte sprechen Sie uns an!